

# Ambassador 20

Model:  
C8420-115  
C8420-240

OPERATION

SERVICE

PARTS

CARE

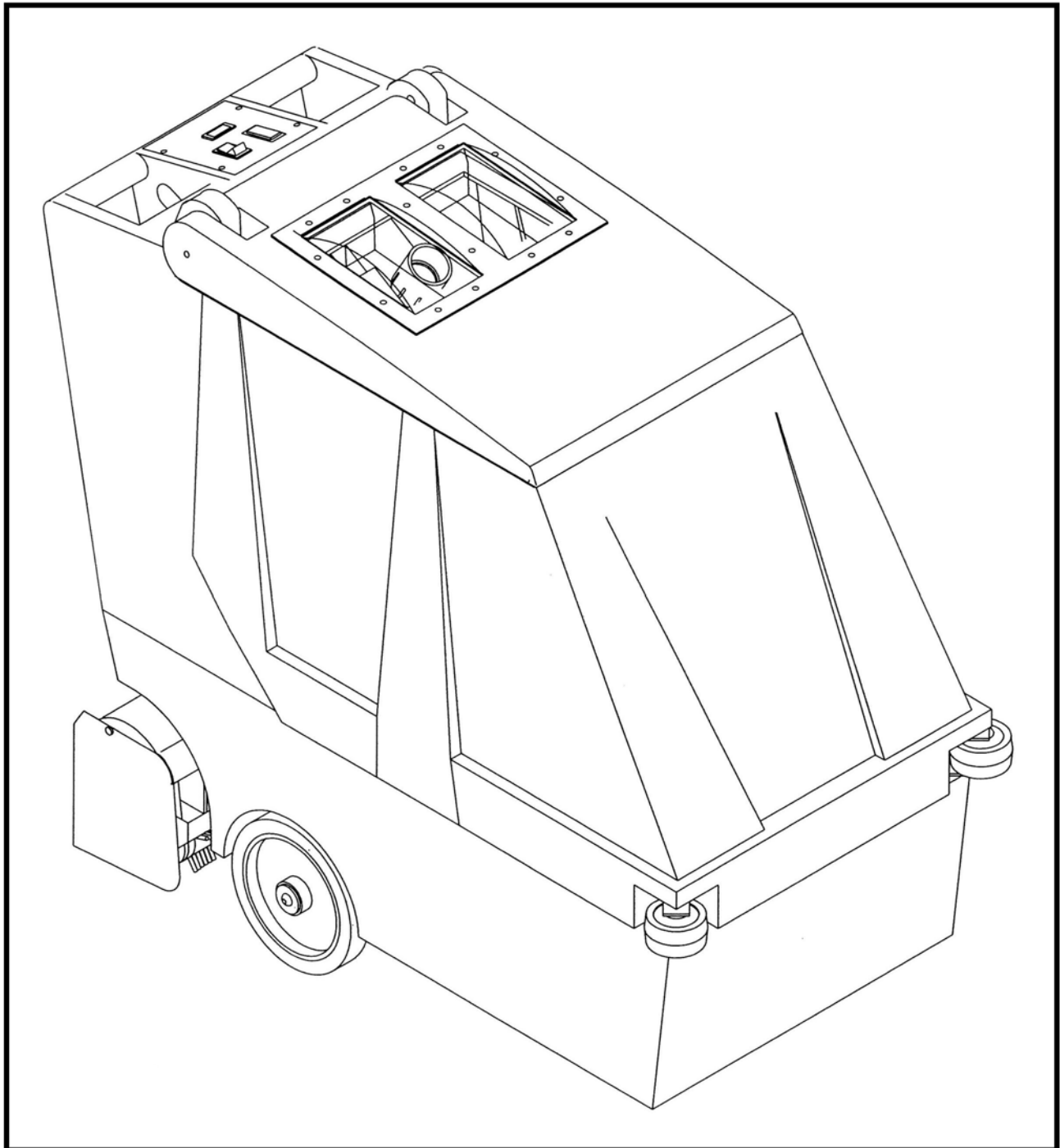

**Minuteman<sup>®</sup>**

This manual is furnished with each new **Minuteman Ambassador 20**. This provides the necessary operating and preventative maintenance instructions. Operators must read and understand this manual before operating or servicing this machine.

This machine was designed to give you excellent performance and efficiency. For best results and minimal cost, please follow the general guidelines below:

- Operate the machine with reasonable care.
- Follow the manufacturer's suggested maintenance instructions as provided in this manual.
- Use original Minuteman supplied parts.

## TECHNICAL SPECIFICATIONS

Model	Ambassador 20
Model #	C8420-115 ; C8420-240
Voltage (AC)	115V 60Hz ; 240V 50/60Hz
Current	12 Amps (115V) ; 7 Amps (240V) (50Hz)
Sound Level	79 dBA @ operator's ear ; 73.6 dBA @ 3 meters
Brush Speed	1040 RPM
Dimensions (LxWxH)	45 1/8" x 20 3/4" x 38 1-4" ; (114.6cm x 52.7cm x 97.2cm)
Weight (gross)	234 lbs ; (106 kg)

# TABLE OF CONTENTS

IMPORTANT SAFETY INSTRUCTIONS.....	4
INSPECTION, WARNINGS, GROUNDING INSTRUCTIONS.....	5
OPERATOR VIEW OF CONTROLS.....	8
OPERATING INSTRUCTIONS.....	9
EXPLODED VIEWS.....	10
WIRING DIAGRAM.....	18
TROUBLESHOOTING.....	20
LIMITED WARRANTY.....	22

## **FOR COMMERCIAL USE ONLY**

### **IMPORTANT SAFETY INSTRUCTIONS**

When using an electrical appliance, basic precautions should always be followed, including the following:

#### **READ ALL INSTRUCTIONS BEFORE USING**

**WARNING:** To reduce the risk of fire, electric shock, or injury:

- Do not leave appliance when plugged in. Unplug from outlet when not in use and before servicing.

#### **WARNING**

To reduce the risk of electrical shock – Do not expose to rain. Store indoors.

- Do not allow to be used as a toy. Close attention is necessary when used near children.
- Use only as described in this manual. Use only the manufacturer's recommended attachments.
- Do not use with damaged cord or plug. If appliance is not working as it should, has been dropped, damaged, left outdoors, or dropped into water, return it to an authorized service center.
- Do not pull or carry by cord, use cord as handle, close a door on a cord, or pull cord around sharp edges or corners. Do not run appliance over cord. Keep cord away from heated surfaces.
- Do not unplug by pulling on the cord. To unplug grasp the plug, not the cord.
- Do not handle the appliance with wet hands.
- Do not put any object into the openings. Do not use if any opening is blocked; keep free of dust, lint, hair, and anything that may reduce air flow.
- Keep hair, loose clothing, fingers, and all parts of the body away from openings and moving parts.
- Do not pick up anything that is burning or smoking, such as cigarettes, matches, or hot ashes.
- Do not use without dust bag and/or filters in place.
- Turn off all controls before unplugging.
- Use extra care when cleaning on stairs.
- Do not use to pick up flammable or combustible liquids such as gasoline or use in areas where they be present.
- Connect to a properly grounded outlet only. See grounding instructions.

### **SAVE THESE INSTRUCTIONS**

## INSPECTION

Carefully unpack and inspect your machine for shipping damage. Each unit is tested and thoroughly inspected before shipment, and any damage is the responsibility of the delivery carrier who should be notified immediately.

## WARNING

- Read Instructions Manual before operating this piece of equipment.
- To reduce the risk of fire use only commercially available floor cleaners and waxes intended for machine application
- Electrical motors and components can cause an explosion when operated near volatile materials and vapors. Do not use this machine near flammable materials such as solvents, thinners, fuels, grain dust, ect.

## ELECTRICAL – 115 VOLT Model C8420-115

This machine is designed to operate on a standard 15 amp. 120-Volt, 60hz, AC circuit. Voltages below 105-Volt AC or above 125-Volts AC could cause serious damage to the motor.

## ELECTRICAL – 240 VOLT Model C8420-240

This machine is designed to operate on a standard 16 amp. type L fused 230-Volt, 50 Hz, AC circuit. Voltages below 200-Volt AC or above 250-Volts AC could cause serious damage to the motor.

## GROUNDING INSTRUCTIONS

- This floor finishing machine should be grounded while in use to protect the operator from electric shock. The machine is equipped with a three-conductor cord and three prong grounding type attachment plug to fit the proper grounding type receptacle. The green (green and yellow) conductor in the cord is the grounding wire. Never connect this wire to anything other than the grounding blade.
- Floor Finishing Machines Rated Less than 150-Volts – If the machine is provided with an attachment plug, as shown in Sketch A, it is intended for use on a 120-Volt (normal) circuit. If a properly grounded receptacle, as shown in Sketch A, is not available, an adapter as shown in Sketch C, is available and be installed as shown in Sketch B if the outlet box that houses the receptacle is grounded. Be sure to fasten the grounding tab with the faceplate screw.
- Floor Finishing Machines Rated More than 150-Volts – If the machine is provided with attachment plug as shown in Sketch D, it is intended for use in nominal 240-Volt circuit. No adapter is available for this plug.

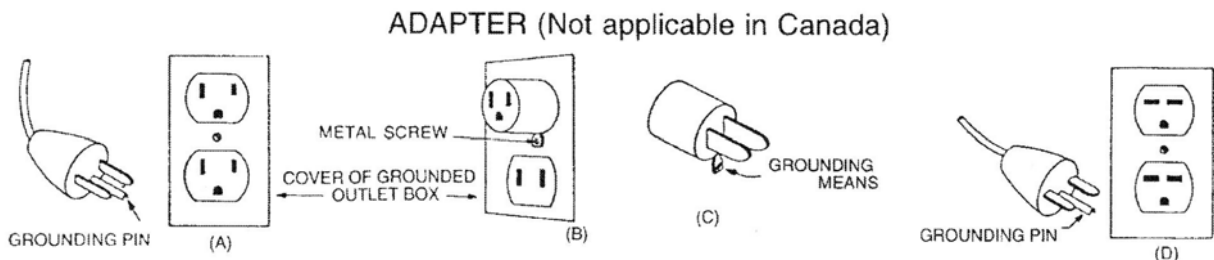

# POUR USAGE COMMERCIAL SEULEMENT

## MODE D'EMPLOI SECURITAIRE

Lorsque l'on utilise un appareil électrique, des précautions de base doivent toujours être suivies telles que:

### BIEN LIRE LE MODES D'EMPLOI AVANT USAGE

**AVERTISSEMENT** - Pour réduire les risques de feu, choc électrique ou blessure:

- Ne pas quitter l'appareil lorsque la prise de courant est branchée. Débrancher de la sortie électrique lorsque la machine n'est pas en usage ou pour en faire le service.

**AVERTISSEMENT** - Pour réduire le risque de choc électrique - Ne pas exposer à la pluie - Entreposer à l'intérieur.

- Ne pas permettre l'usage comme jouet. Etre très prudent lorsque l'appareil est utilisé en présence d'enfants.
- Utiliser tel que prescrit dans le livre d'opération et seulement avec les attachements recommandés par le manufacturier.
- Ne pas s'en servir avec corde ou prise de courant endommagée. Si l'appareil ne fonctionne pas ou a été échappé, endommagé, entreposé à l'extérieur ou déposé dans l'eau, l'appareil devrait être envoyé à un département de service pour inspection.
- Ne pas tirer ou porter par le câble ou se servir du câble comme poignée. Ne pas fermer de portes sur le câble ou tirer le câble près d'objets pointus. Ne pas conduire l'appareil en écrasant le câble et soyez certain de protéger le câble entre toutes surfaces de chauffage.
- Ne pas débrancher en se servant du câble. Pour débrancher tirer sur la prise et non sur le câble.
- Ne pas manipuler la prise ou l'appareil avec les mains mouillées.
- Ne placer aucun objet dans la sortie et ne pas s'en servir si la sortie est obstruée. Eliminer toute poussière, maillon, cheveux ou quoique ce soit qui pourrait réduire le mouvement d'air.
- N'exposer aucun cheveux, vêtement, doigts ou autres aux ouvertures de l'appareil.
- Ne rien ramasser de ce qui brûle ou de fumée tels que cigarettes, allumettes ou cendres en feu.
- Ne pas employer sans filtre de poussière ou autre en position.
- Fermer tous les contrôles après utilisation.
- Soyez très prudent lors du nettoyage d'escaliers.
- Ne pas ramasser de liquide inflammable ou combustible tel que gazoline et ne pas utiliser dans les endroits ou ces derniers pourraient être présent.
- Brancher dans une prise avec une prise de terre seulement. Voir références pour prise de terre.

**CONSERVEZ CES RECOMMANDATIONS  
DE MODE D'EMPLOI**

## INSPECTION

Déballer soigneusement en constatant s'il y a lieu tout dommage apparent. Chacune des pièces d'équipement est entièrement inspectée à l'usine et tout dommage de transit est la responsabilité de la compagnie de transport qui devrait être prévenue immédiatement.

## AVERTISSEMENT

- S.V.P. lire le manuel d'instruction avant d'opérer cette pièce d'équipement.
- Pour réduire le risque d'incendie, se servir de ces appareils uniquement pour usage commercial et avec les produits construits spécifiquement pour usage avec ces appareils.
- Les moteurs électriques peuvent être la cause d'explosion si ils sont utilisés près de matériaux ou de vapeurs explosives. Ne pas opérer près de matériaux inflammables tels que solvant, essence, poussière de grain etc.

## ELECTRICITE - 115 Volt, Modèles C8420-115

Ces appareils sont conçus pour opérer sur un circuit standard de 15 amp. 120 volt, 60 hz, circuit AC. Tout voltage en bas de 105 volts AC ou au delà de 125 volts AC pourrait occasionner des dommages au moteur.

## ELECTRICITE - 240 Volt, Modèles C8420-240

Ces appareils sont conçus pour opérer sur un circuit standard AC de 16 amp., fusible type L 230 volt, 50 hz. Tout voltage en bas de 200 volts AC ou au delà de 250 volts AC pourrait occasionner des dommages au moteur.

## INSTRUCTIONS POUR PRISE DE TERRE

- Ces appareils doivent posséder une prise de mise à terre pour protéger l'opérateur contre les chocs électriques. Cet appareil est muni d'une corde électrique à trois fils et d'un receptacle à trois fourchons et prise de mise à terre pour s'accorder dans un receptacle avec prise de mise à terre réciproque. Le fil conducteur vert (ou vert et jaune) de la corde électrique est le fil designé comme prise de mise à terre. Ne jamais relier ce fil à un fil autre que celui de prise de mise à terre.
- Appareils estimés à moins de 150 volts - Si ces appareils offrent une prise de courant tel que dans le croquis A, ils sont destinés pour utilisation avec un circuit de 120 volts. Si un receptacle avec prise de mise à terre n'est pas disponible tel que montré au croquis A, un adapteur tel que vu au croquis C est disponible et devrait être installé tel que montré au croquis B si la boîte électrique est munie d'une prise de mise à terre. Assurez-vous de bien relier la patte de prise avec la vis.
- Appareils destinés à plus de 150 volts - Si ces appareils offrent une prise de courant tel que démontré au croquis D, ils doivent être utilisés avec un circuit de 240 volts. Aucun adapteur n'est disponible pour cette prise.

ADAPTEUR (Non requis au Canada)

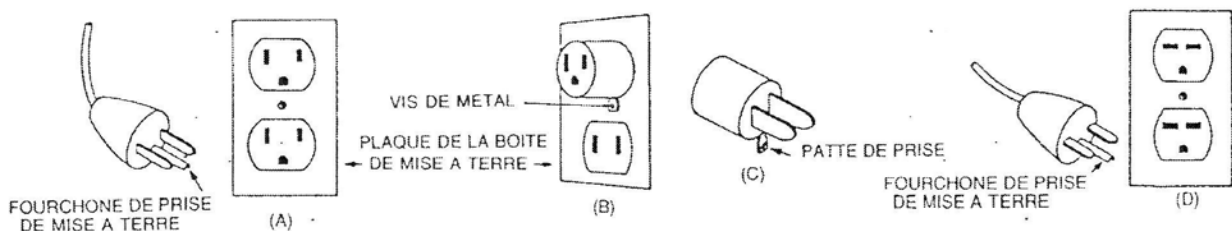

# OPERATOR VIEW OF CONTROLS

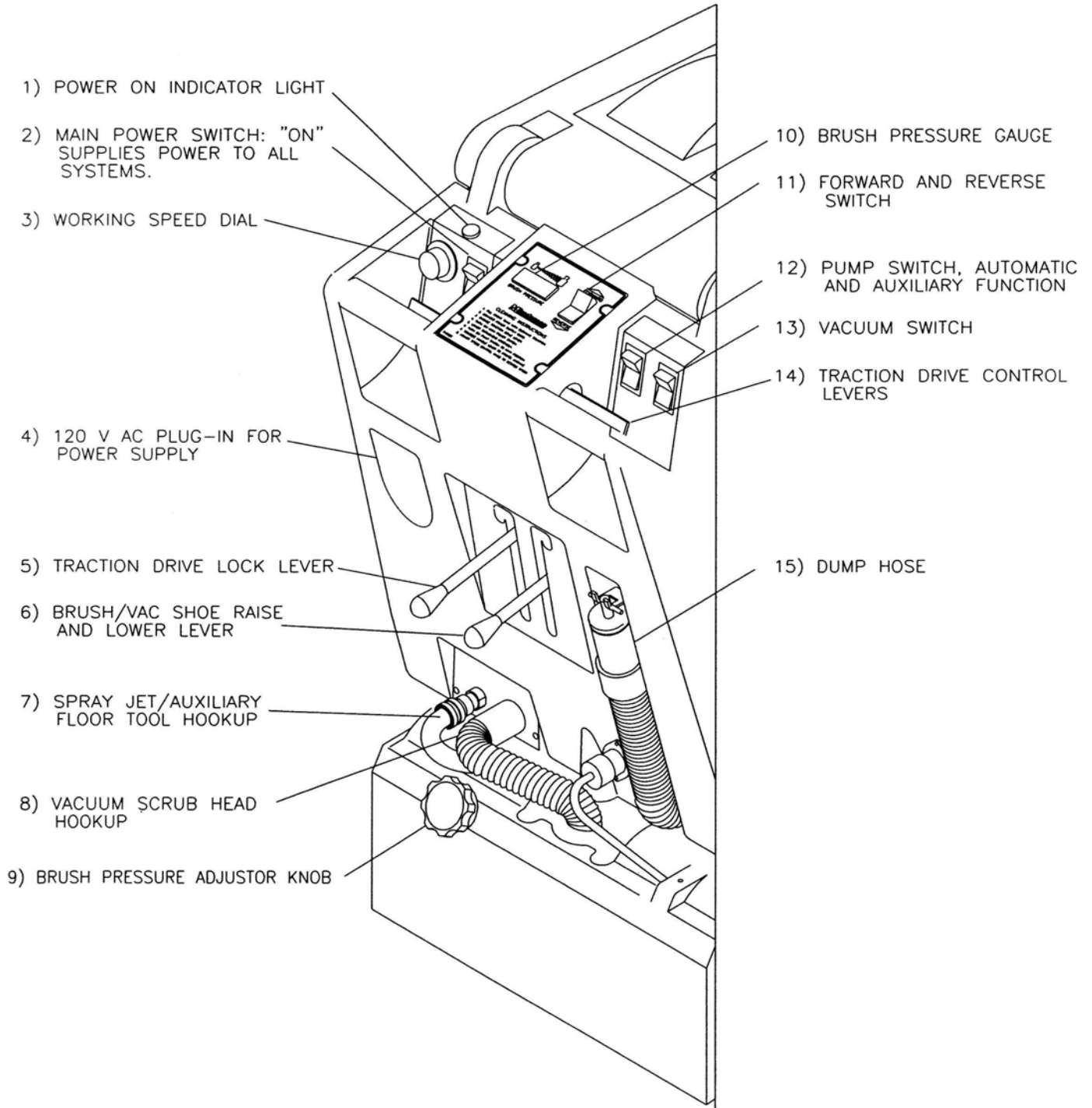



## OPERATING INSTRUCTIONS

1. Filling: Fill the solution tank with the desired amount of water and add liquid cleaning solution to the proper dilution ratio. DO NOT USE powdered cleaning chemicals. Powders are unlikely to dissolve thoroughly, resulting in clogging the inline solution filter. This can reduce or stop water flow to the pump and spray jets.
2. Connect power supply cord to grounded wall outlet, Item # 4
3. Engage traction drive system, Item #5
4. Turn on main power switch, Item #2
5. Lower scrub head assembly, Item #6
6. Turn on pump switch to automatic, Item #12
7. Turn on vacuum, Item #13
8. Set forward/reverse switch to forward, Item #11
9. Engage traction drive control levers, Item #14
10. Adjust forward speed #3
11. Brush pressure can be adjusted + or – by knob, Item #9, and viewing gauge, Item #10 in green zone

### Accessory Attachments:

1. Turn master switch off
2. Disconnect vac hose, see Figure 1 Item #8, and attach vacuum hose from remote tool.
3. Disconnect solution hose, see Figure 1 Item #7, and install remote tool solution hose to the quick disconnect. Turn the pump solution switch, Figure 1 Item #13, to auxiliary.
4. Turn on main power switch.
5. Turn on switch #13 to activate vacuum motor.

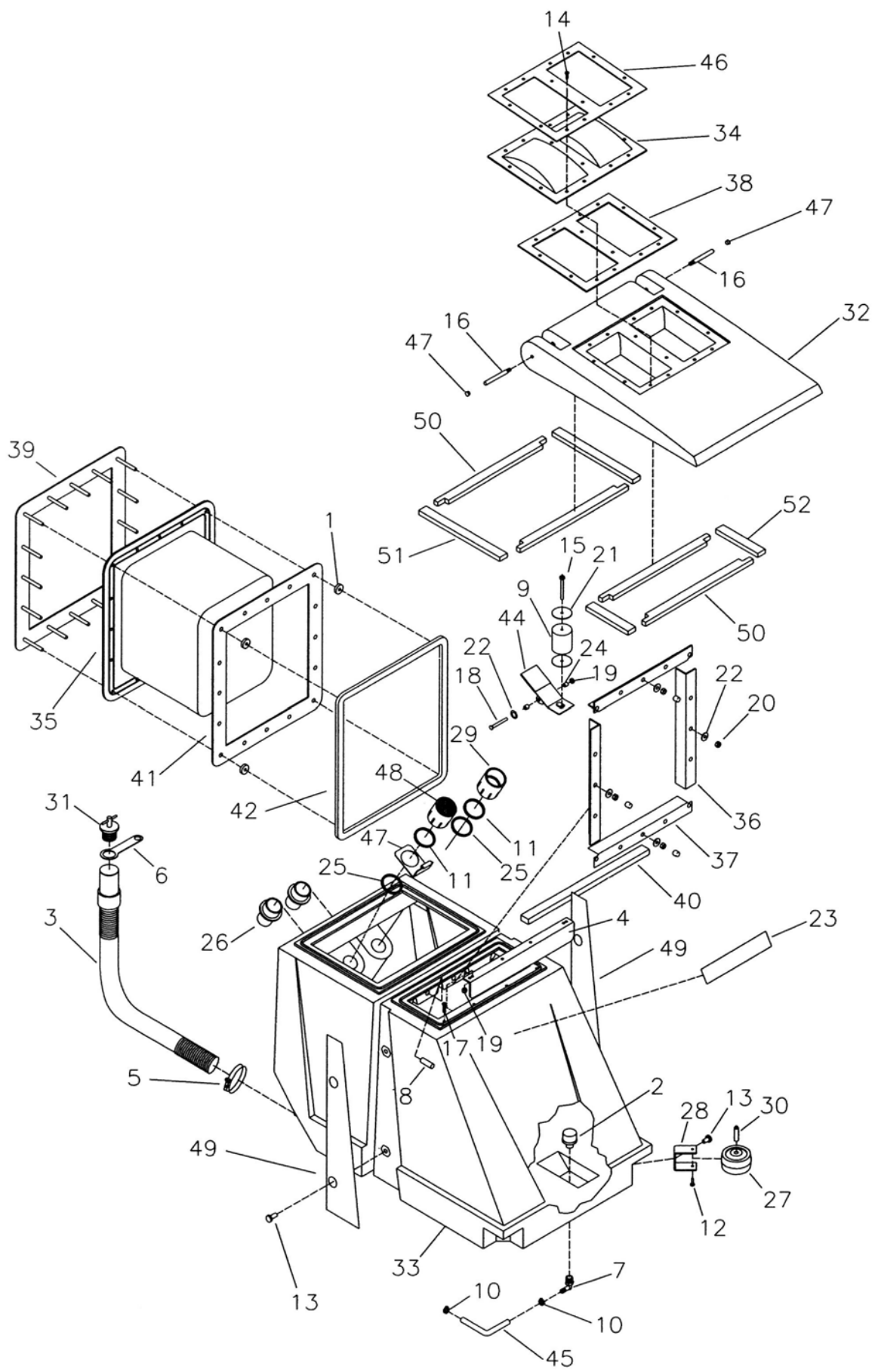

PARTS LIST			
ITEM	PART NO.	REQ'D	DESCRIPTION
1	130029	4	GROMMET .75X.31X.25
2	130118	1	STRAINER-SOLUTION
3	210121	1	DUMP HOSE 200 SERIES
4	260184	1	SUPPORT ANGLE
5	260203	1	CLAMP-HOSE 102120 MURRAY
6	320269	1	STRAP, DRAIN PLUG RETAINING
7	320271	1	FITTING-PP 90 3/8MPT 3/8HOSE
8	420013	1	TUBE 1/2 X 3
9	430089	1	FLOAT 17B
10	450076	2	CLAMP-CRIMP 185R SS
11	450081	2	WSR 1.908 X 2.41 X .03 SS
12	710353	2	SCR-MC 10-32 X .37 ZINC
13	710985	6	SC 3/8-16 X .62
14	711118	14	SCR-ST-A 10 X .75 SS
15	712092	1	SCR 1/4-20 X 2.5 NYL
16	712107	2	SCR-SHOULDER 1/4-20x2.87
17	712563	4	SCR-MC 1/4-20 X 1.00 SS
18	712568	1	SCR-MC 1/4-20 X 2.25 SS
19	712667	5	NUT-HEX NYLOC 1/4-20 SS
20	712683	16	NUT-HEX NYLOC 5/16-18 SS
21	712759	2	WSR-FLT .31 X 1.37 X .06 SS
22	712767	26	WSR-FLT .406 X .75 SS
23	715840	1	DECAL - AMBASSADOR 20
24	762384	2	BUSHING-.277 X .375 X .37 SS
25	828970	2	WSR NEOP 1.87X2.4X.125
26	831812	2	FITTING ABS 1.5MPT 1.5HOSE
27	832896	2	WHEEL-GUIDE
28	832949	2	BRACKET BUMPER
29	833160	1	ADAPTER, PVC 1.5 FPT X 1.5 SLI
30	833254	2	BUMPER WHEEL AXLE
31	833316	1	DRAIN PLUG
32	840001	1	LID TANK AMB 20 BURGUNDY
33	840002-1	1	SOLUTION TANK AMB 20 - BURGUNDY
34	840017	1	DOME AIR / WATER
35	840051	1	BLADDER BAG
36	840054	2	ANGLE, BLADDER SIDE
37	840055	2	ANGLE, BLADDER TOP/BOT
38	840061	1	GASKET, DOME
39	840063	1	FRAME BLADDER MOUNT
40	840069	1	POCKET GASKET
41	840070	1	WASHER PLATE ASSEMBLY
42	840071	1	GASKET SOL/REC
43	840074	1	VALVE PIVOT BRACKET
44	840075	1	FLOAT VALVE
45	840082	1	HOSE 3/8IDx24.00
46	840087	1	COVER PLATE/DOME
47	840095	2	PLUG DOME - HEYCO .312
48	840104	1	FILTER ASY / VAC MOTOR
49	840113	2	SIDE PANEL
50	840119	4	GASKET, LID F/R, PVC FOAM
51	840120	2	GASKET, LID LONG, PVC FOAM
52	840121	2	GASKET, LID SHORT, PVC FOAM

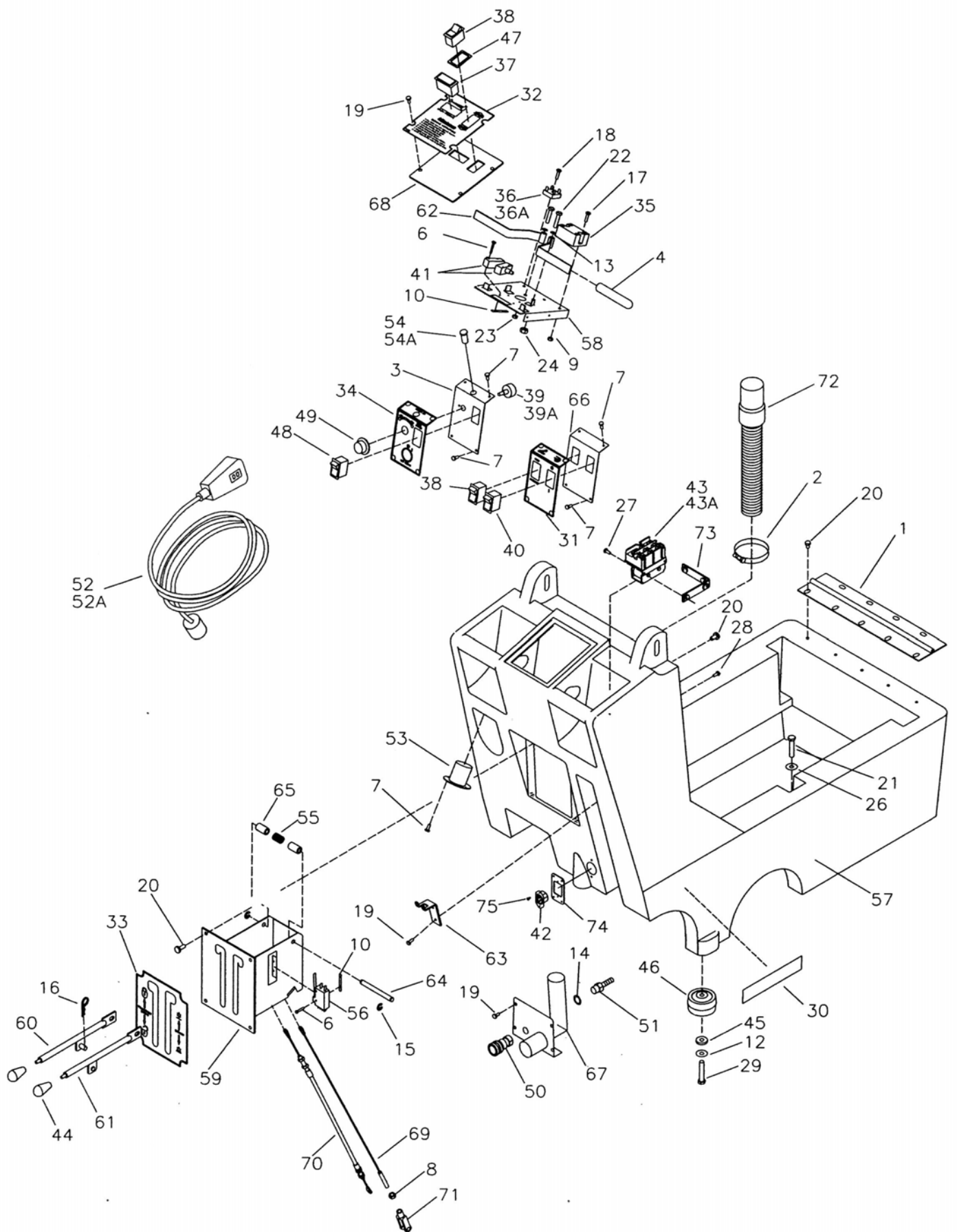

## PARTS LIST

ITEM	PART NO.	REQ'D	DESCRIPTION	ITEM	PART NO.	REQ'D	DESCRIPTION
1	260087	1	HINGE-15"	39A	740787	1	WIRE ASSY.
2	260203	1	CLAMP-HOSE 102120 MURRAY	40	740801	1	SWITCH-ROCKER ON/OFF DPDT
3	260255	1	SPEED CONTROL BRACKET 260TD	41	740806	2	SWITCH-SNAP ACT 20A 1HP
4	260291	2	HANDLE GRIP 260TD	42	741201	1	RECEPTACLE-15A FEMALE SQUARE
5	710204	2	SCR-MC 6-32 X .50 ZINC	43	742145	1	RELAY-MOTOR REVERSE 120V
6	710307	6	SCR-MC 6-32 X 1 ZINC	43A	742146	1	RELAY-MOTOR REVERSE 240V
7	711160	14	SCR-HI/LO #10 X 5/8 ZINC	44	760592	2	KNOB-OVAL TAPERED
8	711322	2	NUT-HEX 5/16-24 ST PL	45	762295	2	BUSHING-ADJ .375 X .62 X .18 Z
9	711372	2	NUT-NYLOC 8-32	46	762331	2	WHEEL,2.5DX1.28W X.38ID
10	711430	3	NUT-TINNERMAN 6-32	47	802657	4	SILICONE BOOT /CARLING SW
11	711506	1	WSR-FLT 5/16 (NARROW) ST PL	48	809754	1	SWITCH-ROCKER
12	711523	2	WSR-WAVE .37 X .68 X .08	49	809874	1	KNOB-SPEED CONTROL
13	711577	4	WSR-FLT .260 X .50 X .020	50	828370	1	BH2-60 FEMALE COUPLER
14	711578	1	WSR-FLT 1/2 BRS	51	828952	1	FITTING PP 1/4MPT 3/8BARB
15	711717	2	RET RING-E EXT .37	52	741205-1	1	CORD ASY, 14/3 75' GFCI-FEM LOCK PLUG
16	711808	2	PIN-HAIRPIN COTTER #13	52A	740477-2	1	CORD ASY-EURO 250V 50FT BLACK
17	712516	2	SC 8-32 X .62 SS	53	830540	1	RECEPTACLE-FLG MALE 15 A 125
18	712537	6	SCR-TR HD 10-24 X .75 SS	54	832859-1	1	INDICATOR LIGHT 115V ASY
19	712540	10	SCR-MC 10-24 X .37 SS TH	54A	832860-1	1	INDICATOR LIGHT ASY 240V
20	712560	13	SCR-MC 1/4-20 X .50 SS NYL	55	833102	1	SPRING-KNOB .60 X .73 X 1.75 Z
21	712566	6	BLT-HH 1/4-20 X 1.25 SS	56	833329SA	1	SWITCH-STAGERED ACTION
22	712569	2	SCR-MC 1/4-20 X 1.50 SS	57	840005-1	1	BASE TANK AMB 20
23	712638	2	NUT HEX 10-24 SS NYLOC	58	840013	1	PLATE LEVER SWITCH
24	712665	2	NUT-HEX 1/4-20 SS	59	840014	1	LEVER CONTROL BOX
25	712759	6	WSR-FLT .31 X 1.37 X .06 SS	60	840022	1	LEVER BAR ASY BELT TNSN
26	712761	6	WSR-FLT .28 X 1.25 X .059 SS	61	840023	1	LEVER BAR ASY VAC SHOE
27	712811	2	SCR-MC 10-24 X .50 ZINC	62	840024	2	LEVER - SWITCH
28	712813	2	SCR-MC 10-24 X .75 ZINC	63	840027	1	HOSE CLIP
29	713048	2	BLT-HH 3/8-16 X 2.50 #5	64	840039	1	LEVER PIVOT PIN
30	715383	2	DECAL, MINUTEMAN	65	840040	2	BUSHING-LEVER BOX .396 X .625
31	715621	1	DECAL-VAC/PUMP	66	840057	1	PLATE, SWITCH
32	715622	1	DECAL-DASHBOARD	67	840079	1	AUXILIARY PLATE ASY
33	715623	1	DECAL-BRUSH/TRACK LIFT	68	840080	1	DASH PANEL
34	715626	1	DECAL-SPEED CONTROL	69	840091	1	CABLE-LIFT
35	740187	1	CONTROLLER-2SP 115/230V	70	840092	1	CABLE-TENSION
36	740202	2	RECTIFIER-BRIDGE 50A 600V IMP	71	840093	1	YOKE
36A	740203	2	RECTIFIER-BRIDGE 50A 1000V	72	840097	1	HOSE GRAY WATER
37	740229	1	GAUGE BR PRESSURE 0-1.5	73	840108	1	BRACKET, RELAY
38	740736	2	SWITCH-3 POSITION	74	840128	1	PLATE - RECEPTACLE
39	740738	1	WIRE ASSY.	75	829214	2	RIVET, 1/8 DIA. REFERENCE POP

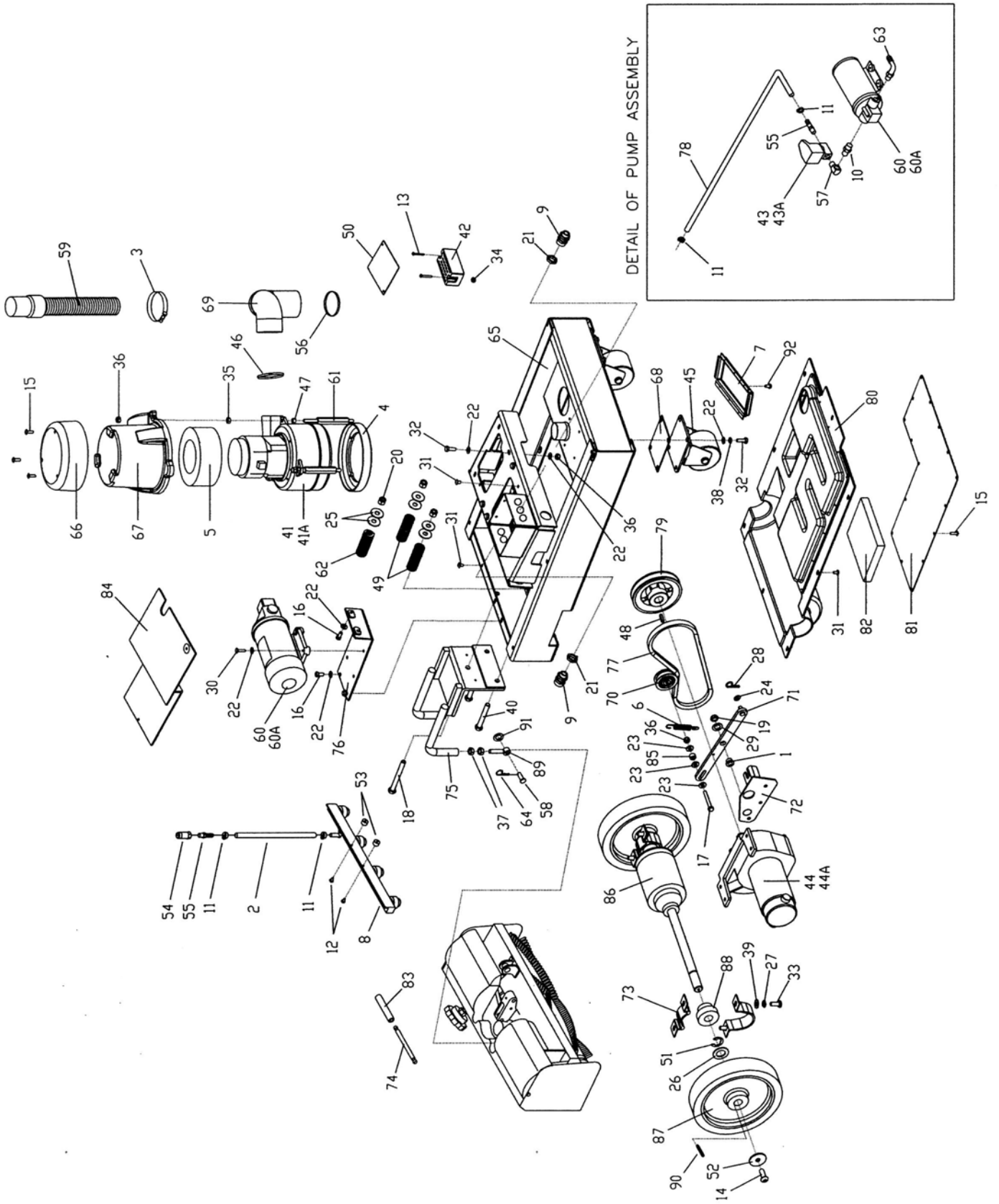

## PARTS LIST

ITEM	PART NO.	REQ'D	DESCRIPTION	ITEM	PART NO.	REQ'D	DESCRIPTION
1	260066	1	BUSHING-FLG .377 X .687 X .406	46	760859	1	CLAMP-HOSE
2	260182	1	HOSE-WIRE REINF 3/8 X 18"	47	762073	3	BUSHING .259 X .375 X .265
3	260203	1	CLAMP-HOSE 102120 MURRAY	48	762375	1	KEY .187 SQ. X .78
4	290017	1	VAC MOTOR GASKET	49	762422	2	SPRING, COMPRESSION
5	380064	1	RING, FOAM	50	805634	1	COVER BOX (741012)
6	430051	1	RETURN SPRING-3.00"	51	809148	2	RETAINING RING - "E" TYPE EXT .75
7	450004	1	AIR MANIFOLD	52	809226	2	WSR-FLT .40 X 1.50 X .12
8	450023	1	SPRAYBAR ASSEMBLY	53	809880	2	BUSHING
9	450050	2	BUSHING-HEYCO .875 X .875 X 1.72 NYL	54	828368	1	COUPLER-MALE BH2-61
10	450059	1	FITTING BRASS 1/4MPT X 1/4MPT	55	828952	2	FITTING PP 1/4MPT X 3/8BARB
11	450076	4	CLAMP-CRIMP 185R SS	56	829067	1	CLAMP-CRIMP 560R
12	710154	2	SCR-MC TR HD 10-32 X .625 SS	57	831306	1	FITTING-90 1/4MPT X 1/4FPT BRASS
13	710307	2	SCR-MC 6-32 X 1.0 ST PL PAN HD	58	831965	2	PIN-CLEVIS 3/8 X 1.63
14	710986	2	SCR-SC 3/8-16 X .87 ST PL	59	832790	1	HOSE-VAC TANK
15	711160	19	#10 X 5/8 HI-LO	60	833067	1	PUMP-100PSI 115V
16	711202	4	BLT-HH 1/4-20 X 0.50 STPL	60A	833068	1	PUMP-100PSI 230V
17	711214	1	BLT-HH 1/4-20 X 2.00	61	833265PLT	3	THREADED SPACER ZINC PLT
18	711280	1	BLT-HH 3/8-16 X 3.50	62	833302	1	DIE SPRING
19	711375	1	NUT-NYLOC 3/8-16 X 1/2 NUT	63	833325	1	FITTING NYLON 90 1/4MPT X 3/8 HOSE
20	711380	3	NUT-NYLOC 3/8-16 NUT	64	833374	2	PIN-HAIRPIN COTTER 3/8
21	711400	2	NUT-PIPE LOCK 1/2	65	840006-1	1	FRAME WELDMENT
22	711504	24	WSR-FLAT 1/4 ID SS	66	840011	1	VAC MOTOR COVER, TOP
23	711505	3	WSR-FLAT 1/4	67	840012	1	VAC MOTOR COVER, BOTTOM
24	711506	1	WSR-FLT 5/16 (NARROW) ST PL	68	840018	2	WASHER PLATE
25	711507	6	WSR-FLAT .37 X 1.12 X .06	69	840042	1	HOSE, VAC MOTOR OUTPUT
26	711512	2	WSR-FLAT .75X1.37X.08	70	840044	1	PULLEY, IDLER
27	711545	4	WSR-HELICAL 5/16	71	840046	1	TENSION ARM ASSEMBLY
28	711808	1	PIN-HAIRPIN COTTER #13	72	840048	1	TENSION PLATE ASSY.
29	712310	1	WSR- FLAT .52 X .87 X .06 PL	73	840049	2	STAMPED STL PILLOW BLK
30	712537	4	10-24 X .75 SS TRUSS HD SCR	74	840053	1	PIN, VAC SHOE LIFT
31	712540	10	SCR-MC TR HD 10-24 X .37 SS	75	840060	1	BRUSH MOUNT ASSEMBLY
32	712562	12	BOLT-HH 1/4-20X3/4 SS	76	840064-1	1	BRACKET - PUMP MOTOR
33	712575	4	BLT-HH 5/16 -18 - .75	77	840066	1	BELT-PIRELLI X-DUTY
34	712605	2	NUT-HEX 6-32 SS	78	840083	1	HOSE-WIRE REINF 3/8 X 31"
35	712665	3	NUT-HEX 1/4-20 SS	79	840088	1	PULLEY, CAST
36	712667	8	NUT, HEX 1/4-20 NYLOC SS	80	840089	1	BAFFLE EXHAUST
37	712695	4	NUT-HEX 3/8-16 SS	81	840090	1	COVER EXHAUST BAFFLE
38	712758	8	WSR-HELICAL 1/4 SS	82	840096	1	FILTER EXHST BAFFLE
39	712767	4	FLAT WASHER .406 ID X .75 OD	83	840098	1	HOSE-NYLO REINF 3/8 X 2.75"
40	713049	2	BLT-HH 3/8-16 X 2.75	84	840105	1	COVER-DRIVE MOTOR
41	740089	1	VAC MOTOR 120V	85	840114	1	SPACER,.500 X .250 X .312
41A	740230	1	VAC MOTOR 240V	86	840115	1	DIFFERENTIAL, KEYED
42	740189	1	TERMINAL BLOCK	87	840116	2	WHEEL-8 X 1.5 X .75 BORE
43	740245	1	SOLENOID-WATER 115V	88	881059	2	BEARING-COLLAR .75 (2PC)
43A	740240	1	SOLENOID-WATER 240V 50HZ	89	833341-1	2	BLT-EYE 3/8-16 X 2.62
44	740732	1	MOTOR-GEAR 140V DC	90	361233	2	KEY-SQ 3/16 X 1-1/2
44A	740786	1	MOTOR-GEAR 240V DC	91	711515	2	WSR-FLT .406 X .812 X .0625
45	760251	2	CASTER-3" X 2"	92	711124	6	SCR-ST-B 10 X .37 NI

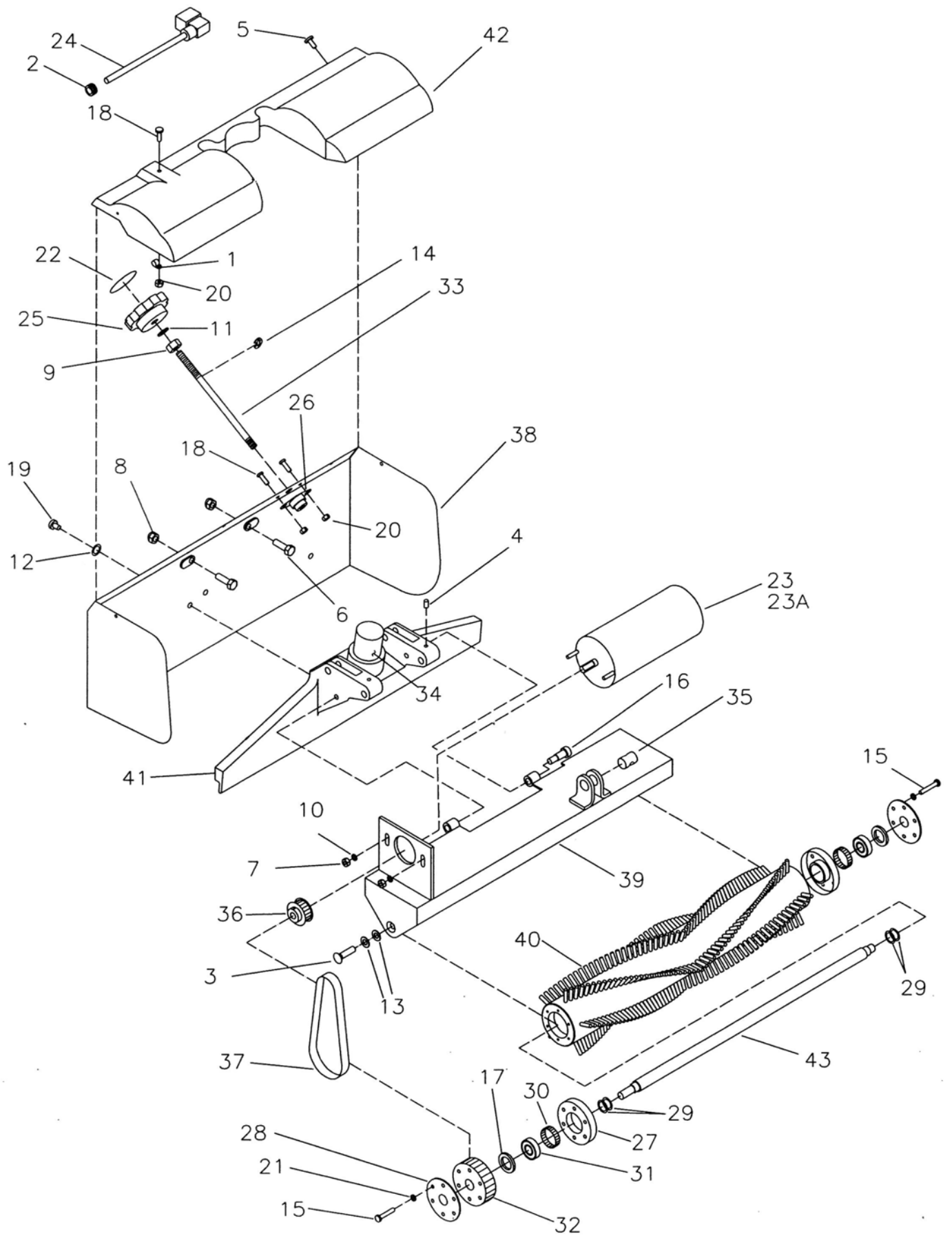



PARTS LIST			
ITEM	PART NO.	REQ'D	DESCRIPTION
1	250039	1	CLAMP-PLASTIC 5/16 3305
2	700287	1	GROMMET
3	710923	2	SC 5/16-18 X .62 ZINC
4	711018	2	SK 10-32 X .37
5	711160	5	SCR-HI/LO #10 X 5/8 ZINC
6	711231	2	BLT-HH 5/16-18 X 1.25
7	711350	2	NUT-NYLOC 10-32
8	711353	2	NUT-ACORN 5/16-18 ST PL
9	711391	1	NUT-HEX JAM 3/8-16 ST PL
10	711504	2	WSR-FLT 1/4 SS
11	711539	1	WSR-EXT LOCK 3/8
12	711554	10	WSR-INT LOCK 1/4
13	711558	2	WSR-INT LOCK 5/16
14	711717	1	RET RING-E EXT .37
15	712066	12	SCR-ST-PAN HD-AB 10 X 1.25 ZIN
16	712081	2	BLT-SHOULDER 5/16-18 X .75 X .
17	712318	2	WSR-FLT .75 X 1.12 X .12 PL
18	712536	3	SCR-MC 10-24 X .62 SS
19	712560	10	SCR-MC 1/4-20 X .50 SS NYL
20	712638	3	NUT HEX 10-24 SS NYLOC
21	712757	12	WSR-HELICAL #10 SS
22	715090	1	DECAL-BRUSH PRESSURE
23	740740	1	MOTOR BRUSH 120VAC
23A	740785	1	MOTOR BRUSH 240VAC
24	740835-1	1	CORD ASSY-AMB 20 BRUSH DECK
25	760034	1	KNOB-ADJ 3/8-16 THREAD
26	760035	1	BEARING-FLG MOUNTED
27	827894	2	CUP BEARING
28	827896	2	COVER BEARING
29	827903	4	WAVE WASHER
30	828145	2	RET RING
31	828588	2	BEARING-.500 X 1.125 X .312
32	832903	1	BR PULLEY 3-40GR 5MM
33	833281	1	THREADED ROD ADJ SS
34	833326	1	VAC TUBE
35	833342	1	SHAFT PIVOT SS
36	833357	1	PULLEY MTR 20TOOTH 5MM
37	833376	1	BELT-HTD 375-5M-09
38	840007	1	VAC SHOE PLTE 12SS
39	840019	1	BRUSH BRACKET
40	840052	1	BRUSH
41	840062	1	VAC SHOE 20"
42	840065	1	COVER-BRUSH SPLASH
43	840081	1	AXLE

# WIRING DIAGRAM

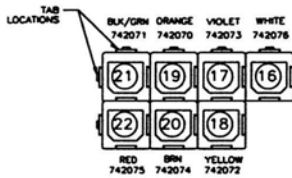
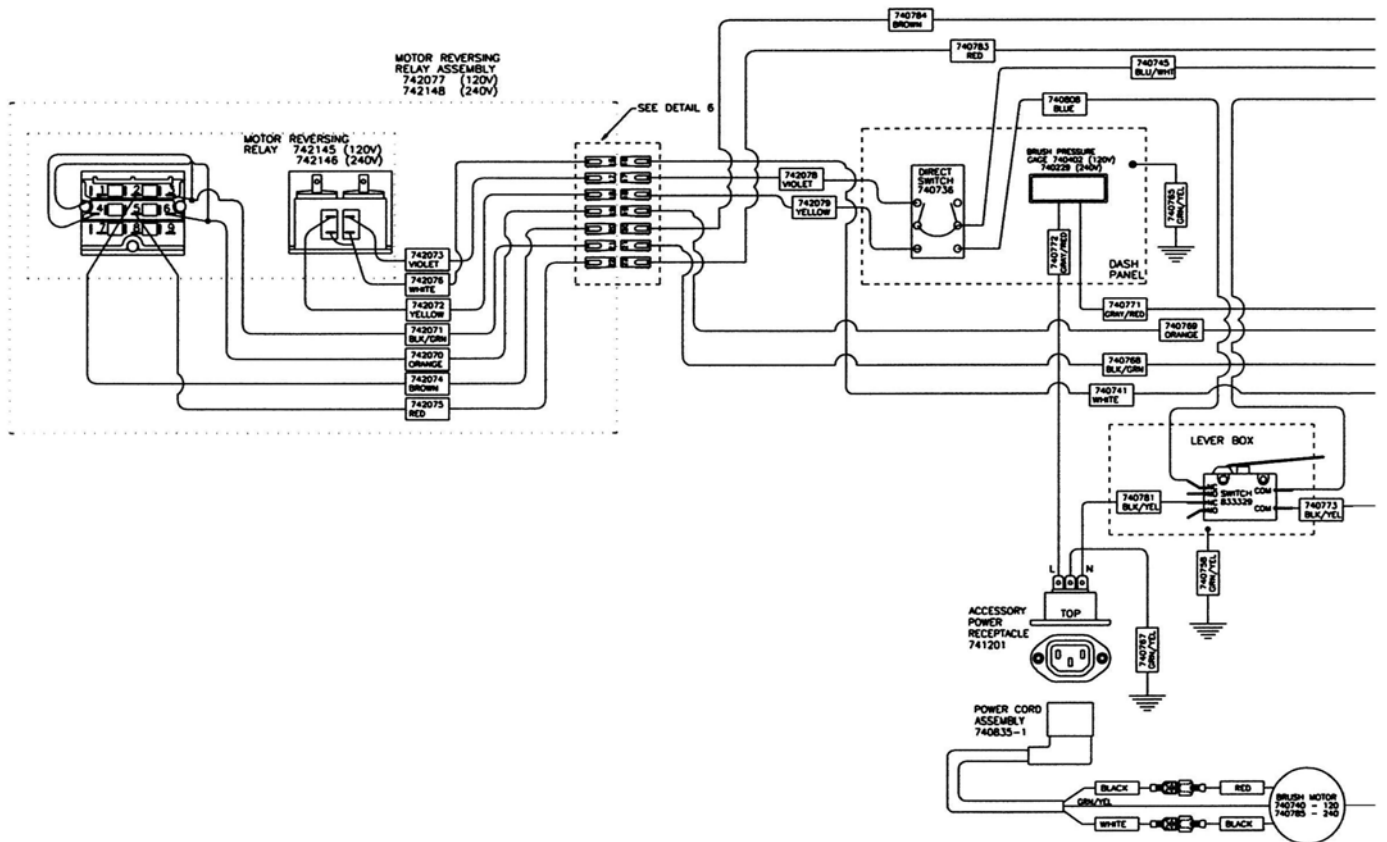

DETAIL 6  
DETAIL FOR WIRE LOCATIONS FROM DIRECTION RELAY  
REAR VIEW OF TERMINAL HOUSING

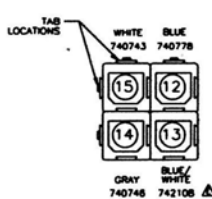

DETAIL 5  
DETAIL FOR WIRE LOCATIONS FROM VAC AND PUMP CONTROLS  
REAR VIEW OF TERMINAL HOUSING

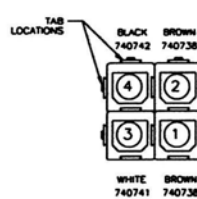

DETAIL 3  
DETAIL FOR WIRE LOCATIONS FROM SPEED/MAIN CONTROLS AND VAC/PUMP CONTROLS  
REAR VIEW OF TERMINAL HOUSING

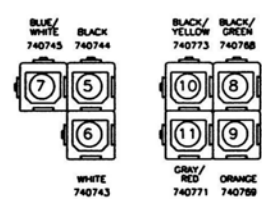

DETAIL 2  
DETAIL FOR WIRE LOCATIONS FROM WIRE HARNESS  
REAR VIEW OF TERMINAL HOUSING

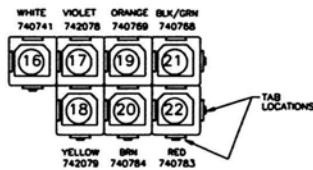

DETAIL 6  
DETAIL FOR WIRE LOCATIONS FROM WIRE HARNESS RELAY  
REAR VIEW OF TERMINAL HOUSING

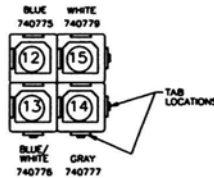

DETAIL 5  
DETAIL FOR WIRE LOCATIONS FROM WIRE HARNESS  
REAR VIEW OF TERMINAL HOUSING

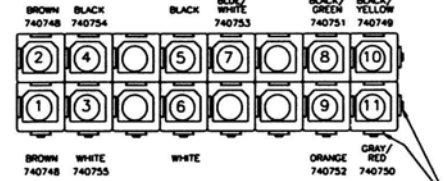

DETAIL 1  
DETAIL FOR WIRE LOCATIONS FROM SWITCH PLATE  
REAR VIEW OF TERMINAL HOUSING

# WIRING DIAGRAM (cont'd)

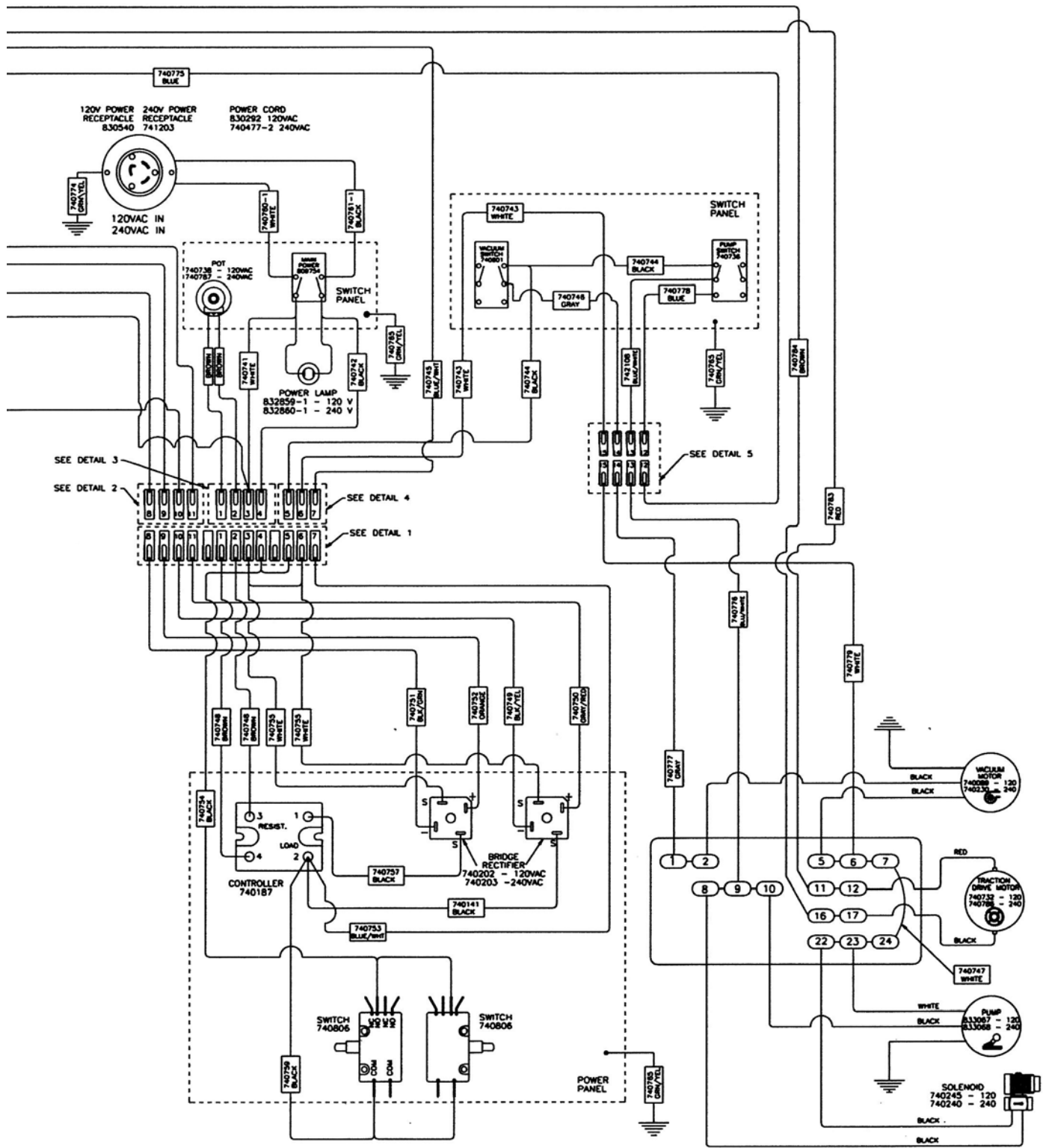

## TROUBLE SHOOTING GUIDE

Use this guide to pinpoint problem areas that may arise with the use of your Ambassador  
20. **CAUTION!** Unplug supply cord before servicing machine components.

### SOLUTION SYSTEM

- I. No water dispensed from spray jets
  - A. The hose connection at the pump for the spray tube may not be tight. Disconnect, then reconnect the fitting, to ensure the fittings snap together securely.
  - B. The solution pump diaphragm may be damaged. Inspect by removing the pump from the pump and inspect the diaphragm for cracks. Replace if required.
- II. Spray intermittent or streaked
  - A. Solution hoses may be clogged. Replaced kinked hoses if found.
  - B. The filter strainer in the solution tank may be clogged. Clean the strainer thoroughly.
  - C. The spray jets may be clogged. Remove the end plug from the spray tube and flush by turning the pump on. Remove the spray jets from the tube and clean as required. Do not clean out the hole in the jet with a pin or wire. This may cause permanent streaking.

### SOLUTION RECOVERY

- I. Solution recovery is reduced.
  - A. Vacuum filter maybe clogged. First check filter recovery tank. Clean if required.
  - B. Check the vacuum hoses for secure fit over the vacuum fittings. Tighten clamps where used. Also check hoses for cracks, kinks or clogging.
  - C. Check the seals on the tank covers for damage. Replace if needed. Make sure cover closes freely without restrictions.
  - D. Make sure the drain hose on the back of the tank is sealed.
  - E. Check the vacuum slot on the scrub head for clogging. Clean out the slot if required.
  - F. Vacuum motor brushes could be worn. Inspect and replace. If motor has run through two sets of brushes, replace the motor.

## **SOLUTION RECOVERY (cont'd)**

II. Pump motor does not run.

- A. Check pressure switch for short circuit. By-pass the pressure switch by connecting the two black leads to the switch to one another, if the motor then runs, replace the pressure switch.

III. Machine fails to run when handle switch is activated.

- A. Speed control maybe shorted out.
- B. Speed control potentiometer may be defective.

## **ELECTRICAL SYSTEM A.C.**

I. Vacuum motor does not start.

- A. Inspect the micro switch lever inside the electrical enclosure to make sure it is functioning properly. As the scrub head is lowered the lever should activate the switch. Bend the switch lever to adjust function if required.
- B. Check motor carbon brush.
- C. Check plugs on power cord.

**FOR ALL THE ABOVE MAKE SURE ALL THE ELECTRICAL CONNECTIONS ARE SECURE. MAKE SURE THE CORD TO THE WALL OUTLET IS SECURE. MAKE SURE THE GFCI IS NOT TRIPPED IF THE UNIT IS EQUIPPED WITH ONE (LOCATED ON POWER CORD).**



## Minuteman International Made Simple Commercial Limited Warranty

Minuteman International, Inc. warrants to the original purchaser/user that the product is free from defects in workmanship and materials under normal use. Minuteman will, at its option, repair or replace without charge, parts that fail under normal use and service when operated and maintained in accordance with the applicable operation and instruction manuals. All warranty claims must be submitted through and approved by factory authorized repair stations.

This warranty does not apply to normal wear, or to items whose life is dependent on their use and care, such as belts, cords, switches, hoses, rubber parts, electrical motor components or adjustments. Parts not manufactured by Minuteman are covered by and subject to the warranties and/or guarantees of their manufacturers. Please contact Minuteman for procedures in warranty claims against these manufacturers.

**Special warning to purchaser** -- Use of replacement filters and/or prefilters not manufactured by Minuteman or its designated licensees, will void all warranties expressed or implied. A potential health hazard exists without original equipment replacement.

All warranted items become the sole property of Minuteman or its original manufacturer, whichever the case may be.

Minuteman disclaims any implied warranty, including the warranty of merchantability and the warranty of fitness for a particular purpose. Minuteman assumes no responsibility for any special, incidental or consequential damages.

This limited warranty is applicable only in the U.S.A. and Canada, and is extended only to the original user/purchaser of this product. Customers outside the U.S.A. and Canada should contact their local distributor for export warranty policies. Minuteman is not responsible for costs or repairs performed by persons other than those specifically authorized by Minuteman. This warranty does not apply to damage from transportation, alterations by unauthorized persons, misuse or abuse of the equipment, use of non-compatible chemicals, or damage to property, or loss of income due to malfunctions of the product.

If a difficulty develops with this machine, you should contact the dealer from whom it was purchased.

This warranty gives you specific legal rights, and you may have other rights which vary from state to state. Some states do not allow the exclusion or limitation of special, incidental or consequential damages, or limitations on how long an implied warranty lasts, so the above exclusions and limitations may not apply to you.

**Cord Electric Group**.....Three years parts, two years labor, ninety days travel  
(Not to exceed two hours)

**Exceptions**..... Port-A-Scrub, one year parts, six months labor  
MPV 13, one year parts  
MPV 14 and 18, two years parts, one year labor  
RapidAir blower, one year parts, one year labor  
Explosion-Proof Vacuum, one year parts, one year labor  
Pneumatic Vacuums, three years parts, one year labor

**Battery Operated Group**..... Three years parts, two years labor, ninety days travel  
(Not to exceed two hours)

**Exceptions**..... Sweepers, one year parts, one year labor, ninety days travel  
(Not to exceed two hours)

**Internal Combustion Group**....One year parts, one year labor, ninety day travel  
(Not to exceed two hours)

**Replacement Parts**.....Ninety days

**Batteries**.....0-3 months replacement, 4-12 months pro-rate

**Polypropylene Plastic Tanks**...Ten years, no additional labor

### ***A Member of the Hako Group of Companies***

111 South Rohlwing Road · Addison, Illinois 60101 USA

Phone 630- 627-6900 · Fax 630- 627-1130

E-Mail, [www.minutemanintl.com](http://www.minutemanintl.com)

**P.N. 988403**  
**Rev \* 01/06**